

# APRON FOLDABLE



Se trata de un producto diseñado para proporcionar soluciones a ascensores con foso reducido donde tanto la profundidad como la ausencia de ruido son importantes.

Se ha diseñado para satisfacer los requisitos de la EN81-1, EN81-21 y la EN81-20, y de manera que pueda adaptarse dimensionalmente a la mayoría de las instalaciones.

This is a product designed to provide a solution to low pit elevators in which both depth and noise comfort are important.

It has been designed to meet the requirements of the EN81-1, EN81-21 y la EN81-20, and it can adapt dimensionally to most of the applications in the field.

---

PROFUNDIDAD / DEPTH

**105mm**

---



## APRON FOLDABLE

Cómo hacer un pedido / How to order:

MOD.	PL	H	L/R	IDIOMA/LANGUAGE
F200	800	140	L	ENG

Mod.	PL	H	L	V	L/R*
F125	600 - 1000	105 - 125	335	645	✓
F200	600 - 1000	130 - 200	320	625	✓
F280	600 - 1000	205 - 280	290	550	✓
F330	600 - 1000	285 - 330	255	465	✓
F450	600 - 1000	330 - 450	255	465	✓

\* L/R: Left Right

L: Left opening door - Looking from landing, apron lock on the right side.

R: Right opening door - Looking from landing, apron lock on the left side.

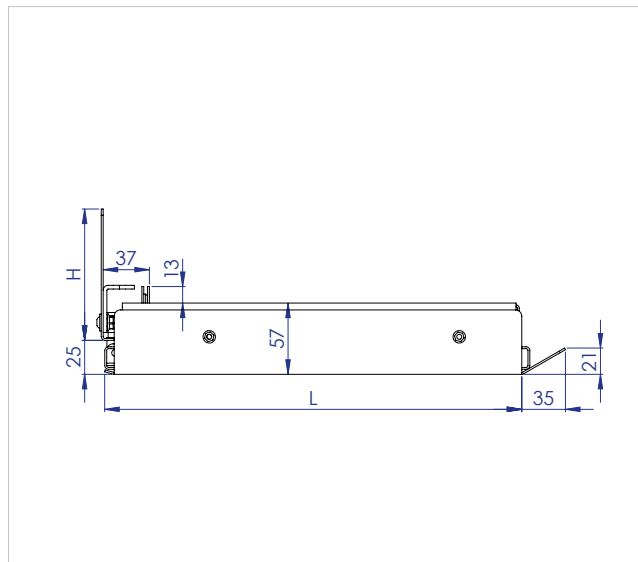
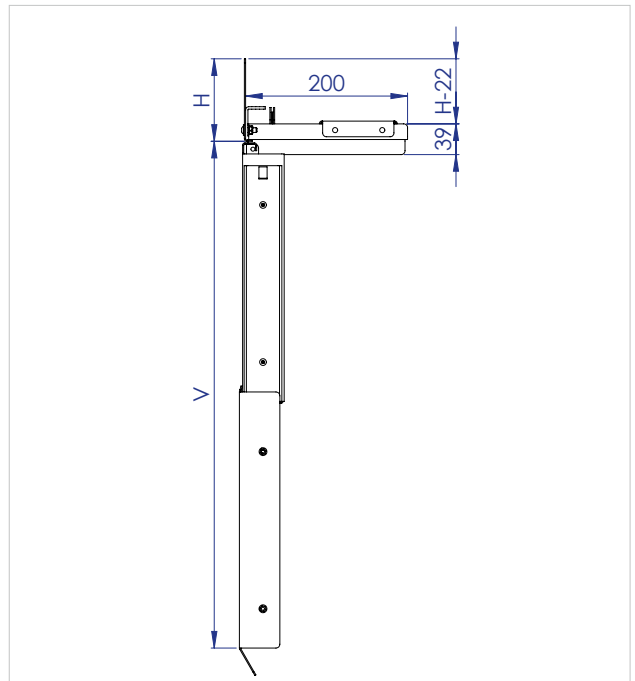
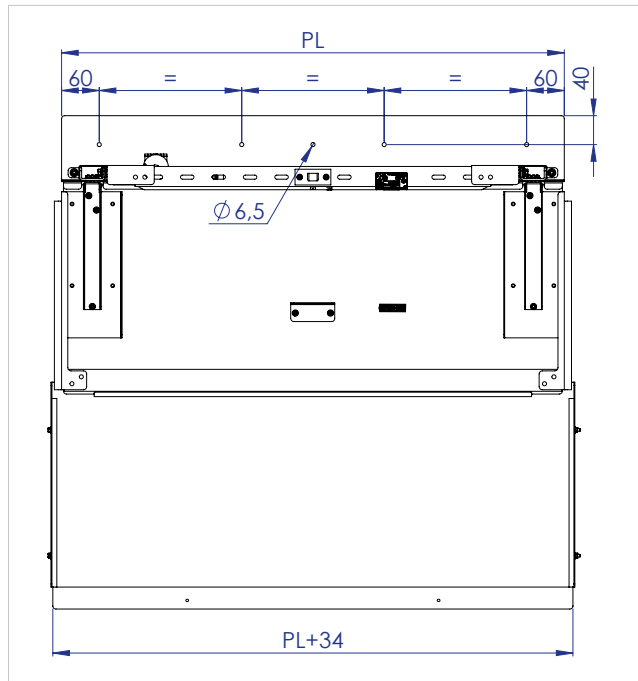

### MODULO DE FIJACIÓN HOW TO FIX

